

MODELS OD-8003 OD-9003 OD-1106 OD-12012 OD-15011

Ultra Silent, High Performance, Attractive Design Grille

Description

Ventilating fan should be ceiling or wall mounted and capable of exhausting air quietly and efficiently. The Ortech Premium Series is HVI and Energy Star certified. It comes with a capacitor start motor which is known for its high efficiency and long lasting reliability. It holds an ETL evaluation and conforms to UL and cUL safety standards.

Housing

Made of rugged 26 GA galvanized steel

Detachable 4 inch (6 inch) polymeric collar which includes a light weight built in back draft damper.

Double hanger bar mounting brackets that are adjustable up to 24 inch span allows for ideal positioning.

Motor/Blower

Plug in permanently lubricated motor- Engineered for continuous operation.

The motor is energy efficient and surpasses the minimum Energy Star requirements for continuous duty operation.

Power rating should be 120 volts and 60 Hz

Fan shall be ETL and cETL listed for tub/shower enclosure when used with a GFCI branch circuit.

Motor comes with a built in overload disconnect for safety and longer motor life.

Our Premium series operates at lower RPM's to give you quieter operation.

Grille

The Premium grille is low profile that has elegance and still able to maintain its simplicity.

Made of a rugged polymeric resin that's known for its long life durability.

Comes with torsion spring clips that helps mount grille evenly.

Typical specification

Ceiling ventilator shall have corrosion resistance galvanized steel housing with 4 point mounting capability.

It shall be ducted to a roof vent or wall cap using 4 inch (6 inch) round pipe.

Blower assembly shall be removable, have a centrifugal type blower wheel and a permanently lubricated motor designed for continuous operation.

Includes an attachable non metallic collar with build in back draft damper.

Air and sound delivery shall meet the HVI certified ratings as per the fan curves attached.

Ortech's Premium ventilators come with permanent split capacitor motor which improves efficiency this is why it has qualified to carry the Energy Star label.



Options

- Flourescent light
- Humidistat
- Motion Sensor
- Speed controller
- Metal Grille

Reference	QTY.	Remarks	Project:
			Location:
			Architect:
			Engineer:
			Contractor:
			Submitted by:
			Date:

CERTIFICATIONS



MODELS OD-8003 OD-9003 OD-1106 OD-12012 OD-15011

Model Number	OD-8003		OD-9003		OD-1106		OD-12012		OD-15011	
Static Pressure in inches w.g.	0.1	0.25	0.1	0.25	0.1	0.25	0.1	0.25	0.1	0.25
Air Volume (CFM)	80	65	90	73	110	87	126	105	150	136
Noise (sones)	0.3	N/A	0.3	N/A	0.6	N/A	1.2	N/A	1.1	N/A
Fan Watts	25W		25W		35W		39W		43W	
Duct Diameter	4"								6"	
Power Rating(V/Hz)	120/60									

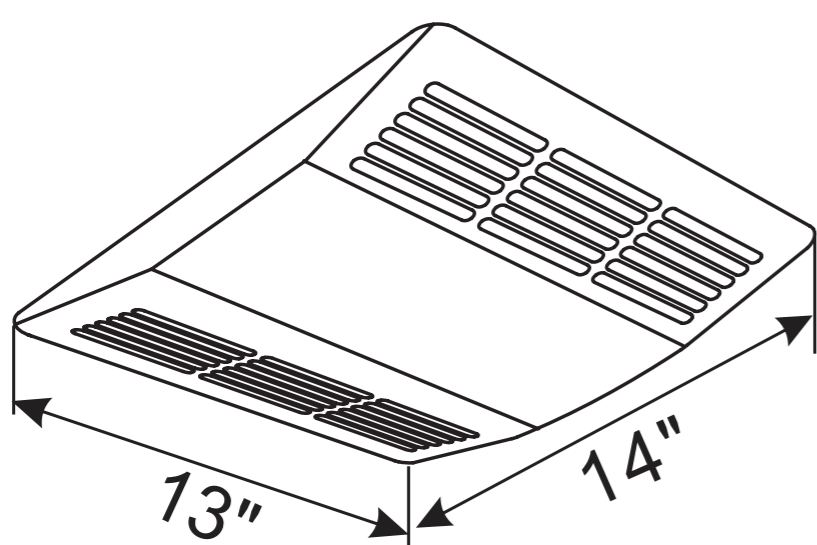
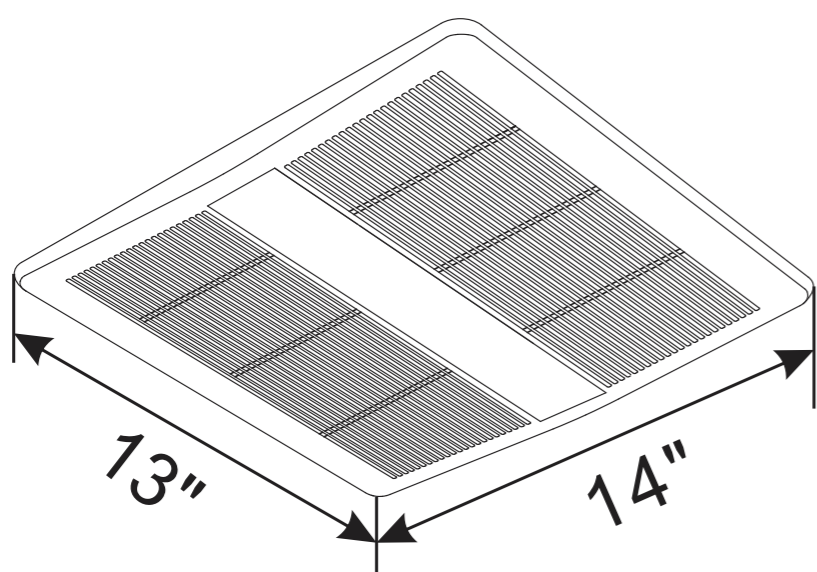
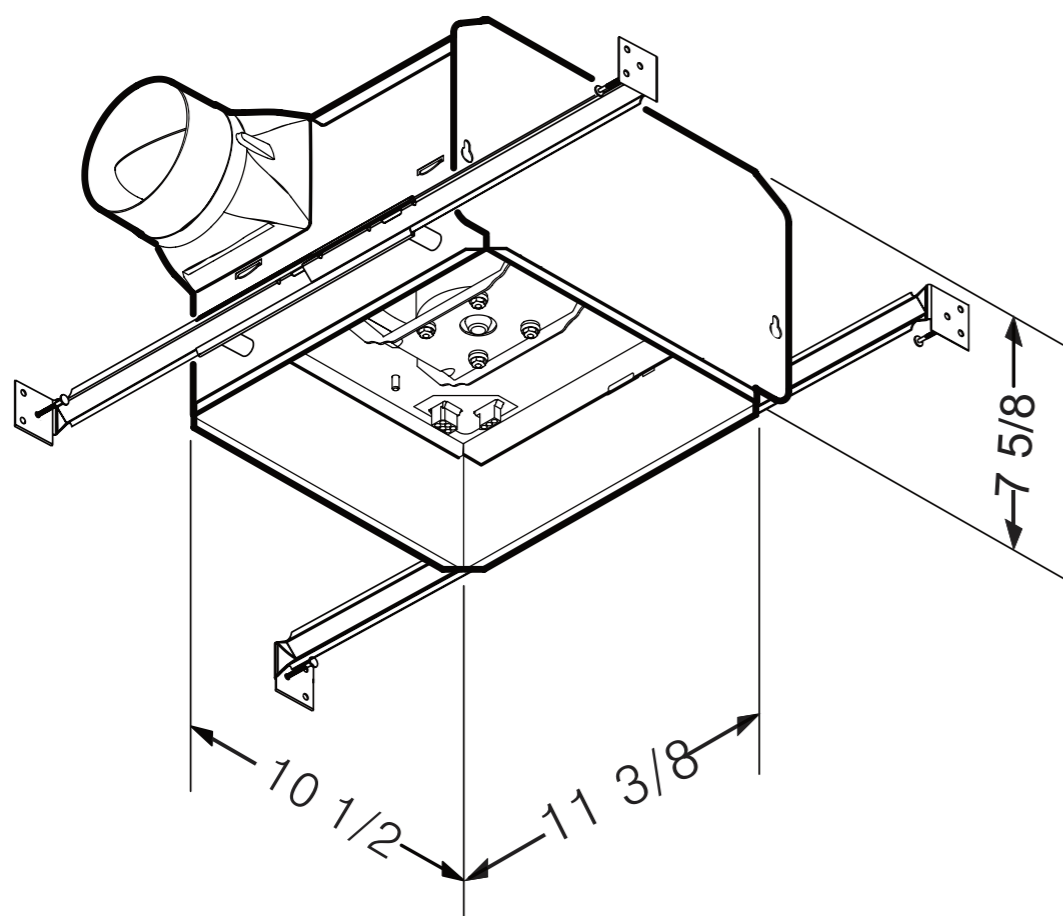

OPTIONAL METAL GRILLE

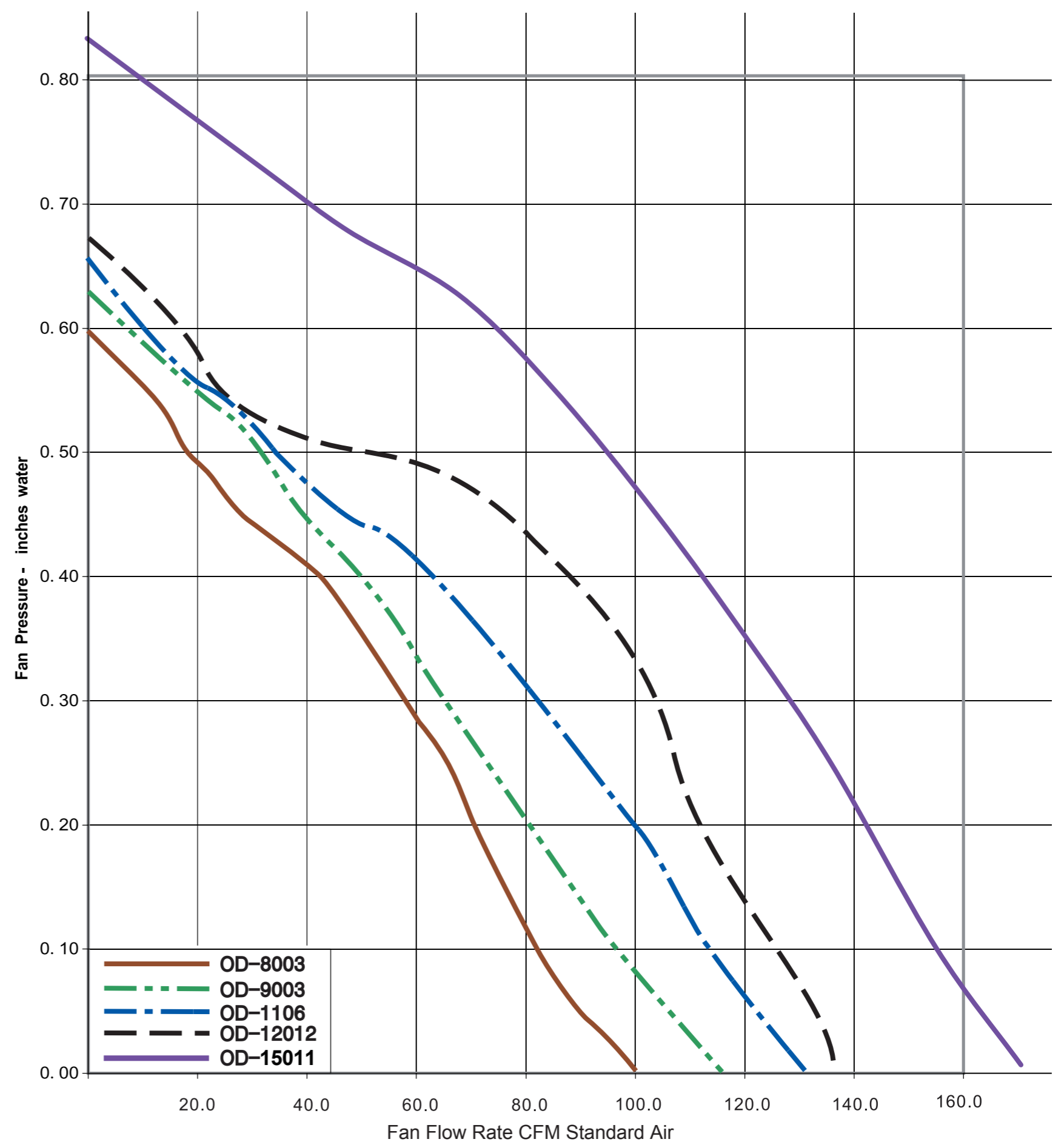

ORTECH INDUSTRIES INC.

604-543-6473-TEL-1-888-543-6473

604-599-6201-FAX-1-888-541-6474

33-13290 78 AVE

SURREY, BC V3W OH6

CANADA



www.ortechlighting.com

CERTIFICATIONS

