



P40-R Series

U-Tube Residential Garage Heater



The perfect heating solution for car enthusiasts and hobbyists!

Infrasave's residential garage heater provides the perfect comfort for your garage and workshop all year round and eliminates condensation that can damage your tools.

The innovative infrared radiant tube heater design of the **P40-R** offers an efficient heavy duty garage heater that is economical yet ideal for garage and workshop applications by keeping your garage floor, tools, and equipment warm and dry throughout the winter.

Experience Counts: Infrasave is the worldwide market leader and most trusted brand with over 2 million heating appliances sold.



Features

- Pre-assembled for an easy installation right out of the box
- Overhead mounting leaves more space in the garage and workshop
- Whisper quiet operation
- Low clearances and hanging heights to easily mount in any garage or workshop

Optional Accessories See back for more details.

- Suspension Hardware
- Hanging Chain
- 24 Volt Thermostat

Contact us today for a **FREE** heated garage quote!

P40-R Series - Technical Specifications & Accessories

Information below is intended only as a reference and should not be used when installing equipment. Please ensure you locate the most recent instruction manual for accurate and up to date information.

Clearances to Combustibles

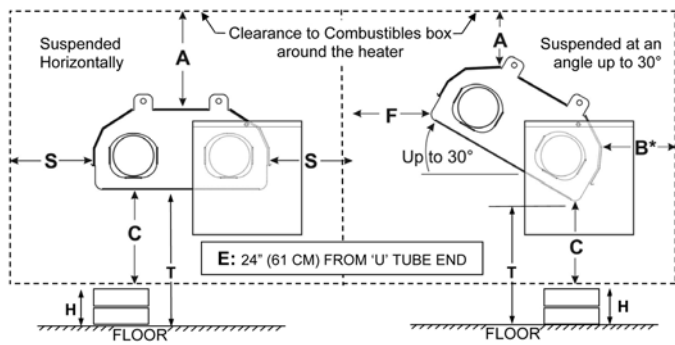

MODEL	SUSPENDED HORIZONTALLY			SUSPENDED AT AN ANGLE UP TO 30°				
	A: TOP inches (cm)	C: BELOW inches (cm)	S: SIDES inches (cm)	A: TOP inches (cm)	C: BELOW inches (cm)	F: FRONT inches (cm)	B: BACK AT 30° inches (cm)	B: BACK < 30° inches (cm)
P40-R	5 (12.7)	53 (135)	24 (61)	5 (12.7)	53 (135)	36 (91.5)	12 (30.5)	24 (61)
E: 'U' END of Heater: 24" (61 cm) (horizontal or angled)								

Dimensions and Specifications

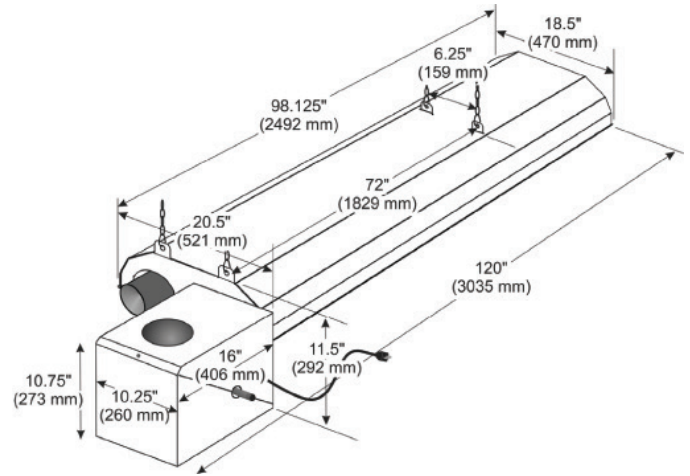

MODEL	INPUT BTU/HR U.S.A.* SEA LEVEL TO 2,000' CANADA*: SEA LEVEL TO 4,500'	HEATER LENGTH	SHIPPING WEIGHT (LBS)
P40-R	40,000	10'	100

* HIGH ALTITUDE: De-rate heater 4% for each additional 1,000 ft. of elevation

Gas Pressure	Line Minimum:	5" W.C. NG	11" W.C. LP
	Line Maximum:	14" W.C. NG	14" W.C. LP
Manifold:	3.5" W.C. NG	10" W.C. LP	
Gas Inlet	1/2"		
Flue & Air Vent	4"		
Electrical	120V, 60 Hz, 145 VA, 4 ft. cord and plug		

Heater Information

BURNER: 40,000 Btu/h Natural Gas (optional conversion kit for LPG), 120V 3-Pronged Plug, 24V Thermostat with 20 ft of 18/2 wire;

TUBE / REFLECTOR SYSTEM: Corrosion resistant aluminized steel construction, 4 inch diameter U-tube provides 17 ft of heat exchange tube in compact 10 ft length; includes 4 ft Lion Chain and four safety snap hooks.

Note: This heater is approved as a Vented Room Heater suitable for residential use

- Overhead suspended type
- ANSI/CSA Standards and Code requirements do not allow direct connection of an outside combustion air duct to the heater
- Rigid connection to the gas supply is in compliance with Gas Code requirements
- Optionally, an installer may choose to connect to the gas supply using a metallic flexible gas connector

What's in the Box?

24 volt Luminous Digital Thermostat	QTY: 1
Thermostat Wire - 20'	QTY: 1
Safety Snap Hooks	QTY: 4
#2 Lion Chain x 4 ft. - 115 LBS Work Load	QTY: 1

Optional Accessories

4" horizontal flue vent terminal (wall)	JA-0528-XX
TruTemp infrared setback thermostat	JM-0150-XX
Field Conversion Kit - NG to LP	JS-0555-XA
Flexible Gas Connector 1/2" x 24"	JL-0771-XX

Distributor info:

Additional resources:



Installation Manual



Find a Distributor



Contact Us

Our customers include:



USA: 2 Schwank Way, Waynesboro, GA 30830 | Canada: 5285 Bradco Blvd. Mississauga, ON L4W 2A6
Tel: 1-877-446-3727 | Fax: 1-866-361-0523 | www.infrasave.com | csr@infrasave.com



M120114 RL: v1.2 RD: Dec-2014